

SECTION A-A

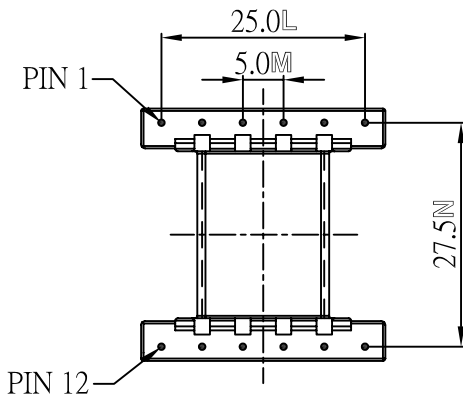

REVISIONS				
ISSUE	SYM	DATE	DRAFTER	CHECKER

NOTE:



樹林企業股份有限公司
TAIWAN SHULIN ENTERPRISE CO., LTD

MODEL

EFD-30-3

MATERIAL

PHENOLIC

WEB: www.bobbin.com.tw

UL RATING

UL94V-0

TOLERANCE

e-mail: shulin@bobbin.com.tw

PIN MATERIAL

CP WIRE

.X±0.2

(TAIWAN TAIPEI) TEL:(886)2-2223-1500 FAX:(886)2-2222-4646

EDITION

1.0

.XX±0.15

(CHINA DONGGUAN) TEL:(86)769-7730-785 FAX:(86)769-7312-387

DATE

2003/5/27

PIN PITCH±0.1

(CHINA SUZHOU) TEL:(86)512-6621-0580 FAX:(86)512-6621-0685

SCALE

1/1

UNIT

MM